

# TRAITEMENT

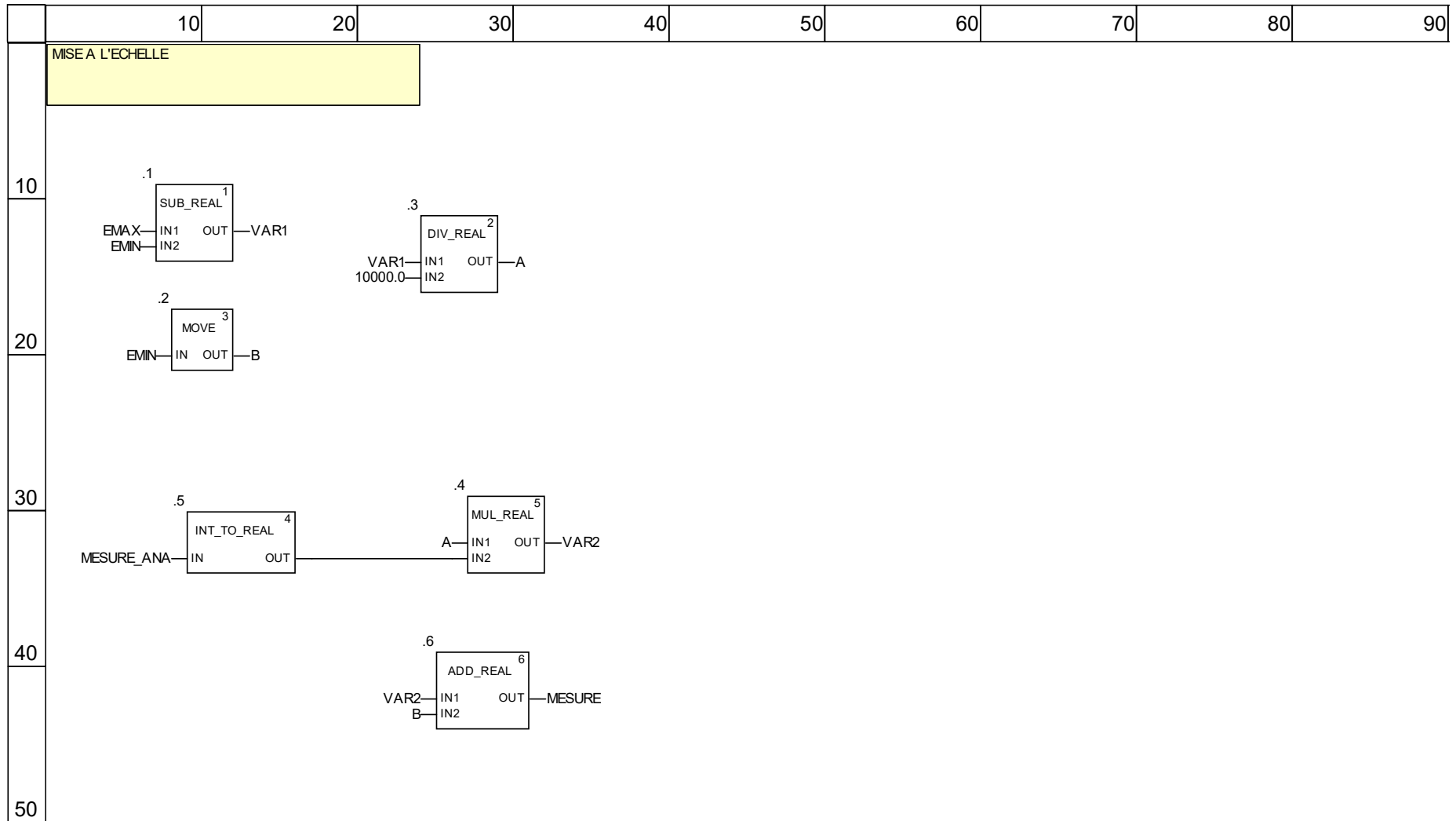

# TRAITEMENT

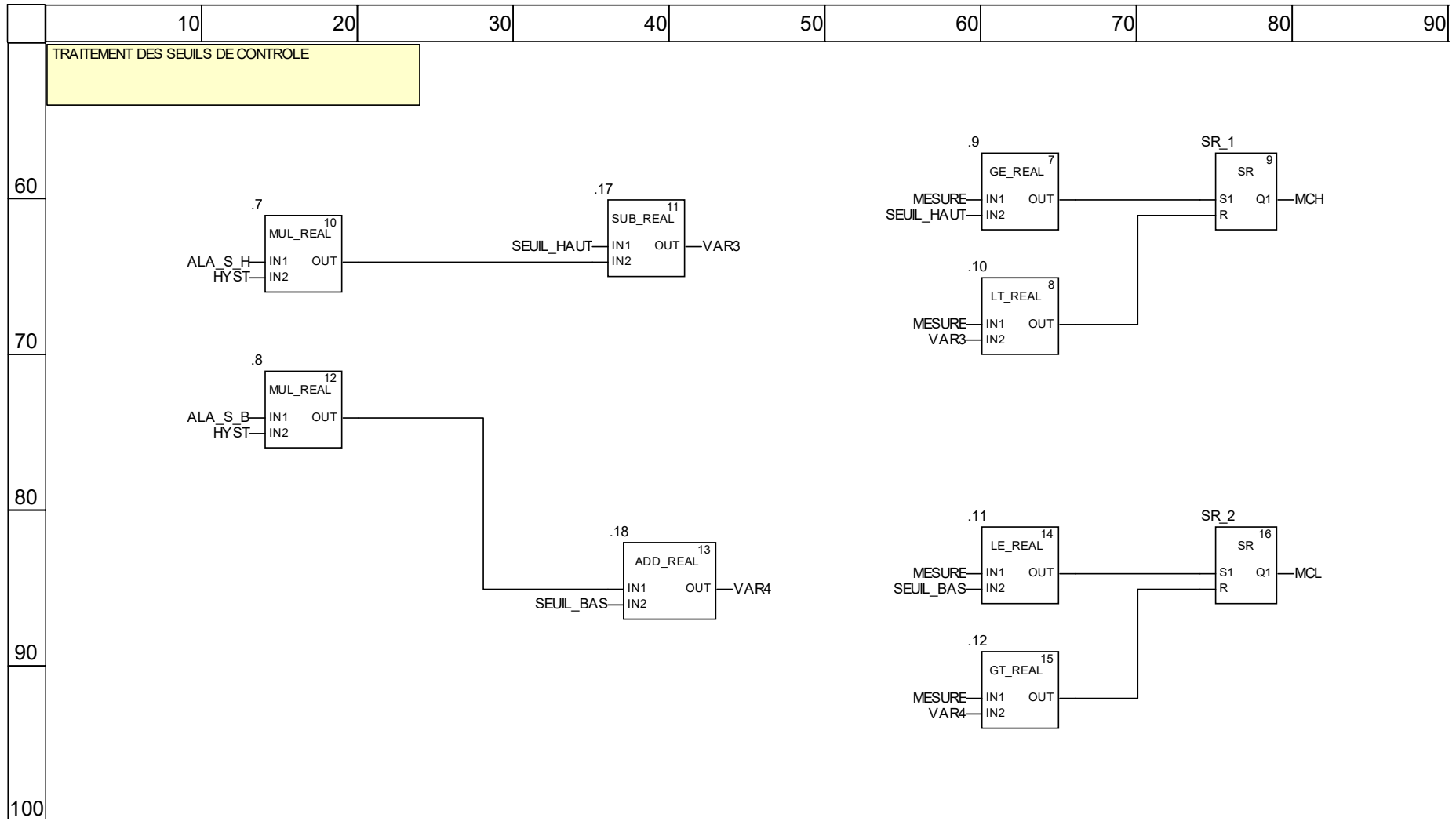

# TRAITEMENT

	10	20	30	40	50	60	70	80	90
--	----	----	----	----	----	----	----	----	----

TRAITEMENT DES ALARMES

110

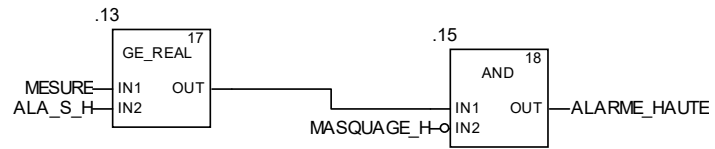

120



130

# POMPE

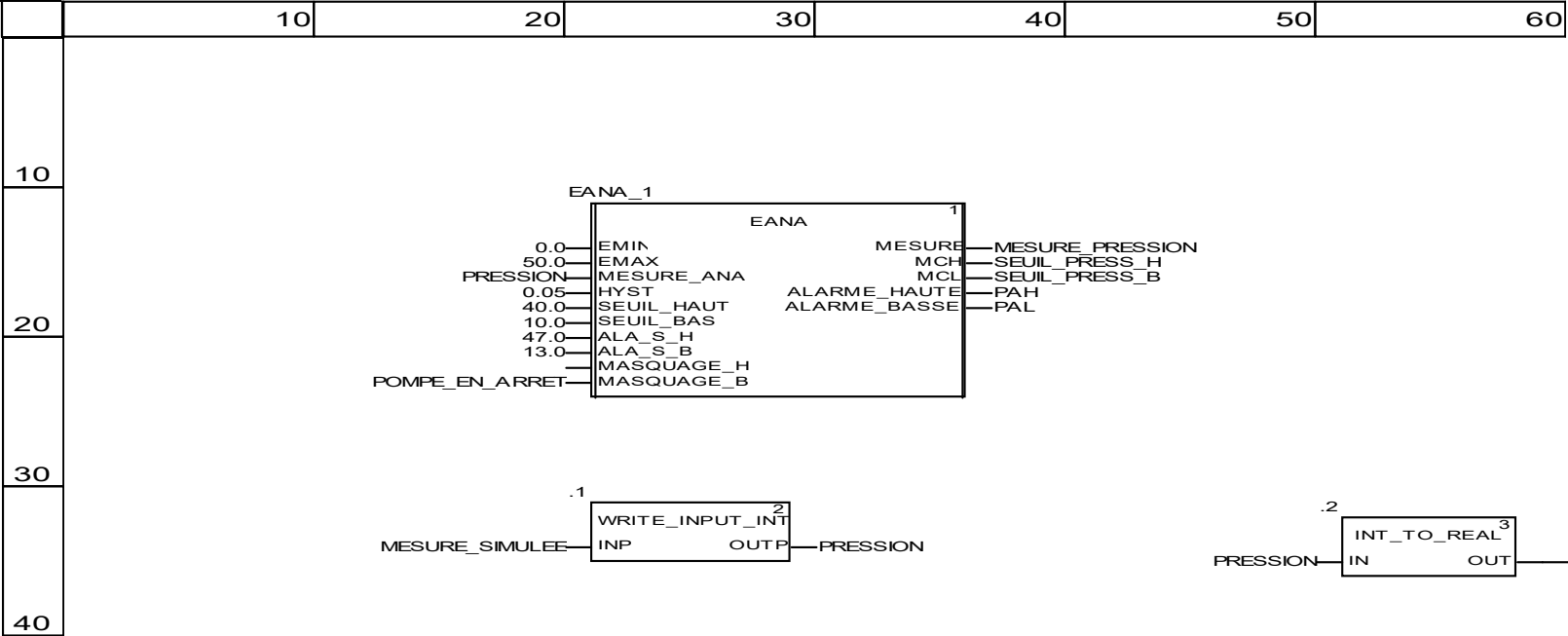

# POMPE

